

## DESCRIPTION

YB1161 is a high efficiency synchronous step-up converter with ultra-low quiescent current down to 1μA. It is capable of delivering at least 2W of power from a low voltage source, i.e. 0.4A at 5V output. It also features a true-shutoff function that disconnects the input from output, during shutdown and output short-circuit conditions. This eliminates the need for an external MOSFET and its control circuitry to disconnect the input from output and provides robust output overload protection.

A switching frequency of 1.4MHz minimizes solution footprint by allowing the use of tiny and low profile inductors and ceramic capacitors. An internal synchronous MOSFET provides highest efficiency and with a current mode control that is internally compensated, external parts count is reduced to minimal. With the ultra-low Iq feature, YB1161 is ideal for solution that requires low standby power and compact board size such as IoT applications.

YB1161 is housed in a SOT23-6 and DFN2x2-6 package

## FEATURES

- ◆ Ultra low IQ when No Switching :1uA for adjustable version and 1.2uA for fixed voltage version
- ◆ 0.8V Startup
- ◆ 5V/0.4A Output Capability at Vin=3V
- ◆ Output to Input Reversed Current Protection
- ◆ Up to 94% Efficiency
- ◆ Internal Synchronous Rectifier and Output Disconnect
- ◆ Short-circuit Protection
- ◆ Adjustable version and Fixed voltage version
- ◆ SOT23-6 & DFN2x2-6 Package

## APPLICATIONS

- ◆ Tablet, MID
- ◆ Smart Phone
- ◆ Power Bank

## TYPICAL APPLICATION

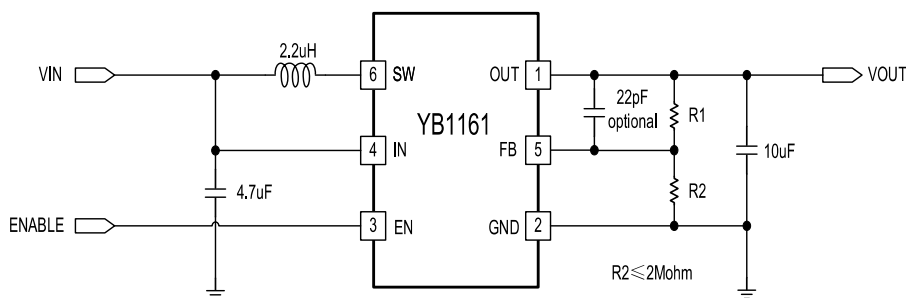

\*Pin number is just for SOT23-6 package,adjustable version

\*For fixed voltage version,R1,R2 and 22pF are not needed and pin5 is NC.

PART No.	Version	PACKAGE	TOP MARK	Pcs/Reel
YB1161S2G	Adjustable	SOT23-6	PBYW	3000
YB1161V33S2G	Fixed 3.3V Output	SOT23-6	PLYW	3000
YB1161V50S2G	Fixed 5.0V Output	SOT23-6	PVYW	3000

**1.4MHz SOT23-6 1uA Ultra low IQ,Synchronous Boost**

**PIN CONFIGURATION**

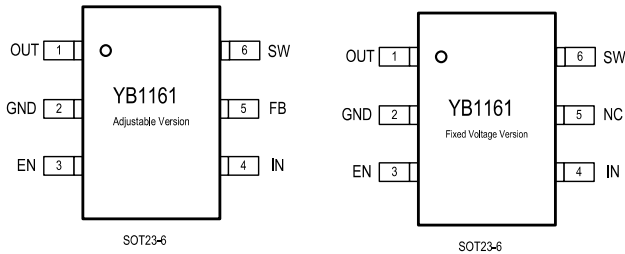

**ABSOLUTE MAXIMUM RATINGS**

(Note: Exceeding these limits may damage the device. Exposure to absolute maximum rating conditions for long periods may affect device reliability.)

IN OUT, SW, FB, EN Voltage.....	-0.3V to 6.5V
SW to ground current .....	Internally limited
Operating Temperature Range .....	-40°C to 85°C
Storage Temperature Range.....	-55°C to 150°C
Thermal Resistance $\theta_{JA}$ $\theta_{JC}$	
SOT23-6.....	180.....90.....°C/W
DFN2x2-6.....	80.....30.....°C/W
Lead Temperature (Soldering 10sec) .....	260°C
ESD HBM (Human Body Mode) .....	2KV
ESD CDM (Charged Device Mode) .....	1KV

**ELECTRICAL CHARACTERISTICS**

( $V_{IN}$ =3.6V,  $V_{OUT}$  = 5V, unless otherwise specified. Typical values are at  $T_A$  = 25°C.)

PARAMETER	CONDITIONS	MIN	TYP	MAX	UNITS
Quiescent Current at OUT, adjustable version	$V_{EN}=V_{IN}$ , No load, Not switching		1	2	$\mu$ A
Quiescent Current at OUT, fixed voltage version	$V_{EN}=V_{IN}$ , No load, Not switching		1.2	2.5	$\mu$ A
Quiescent Current at IN, fixed 3.3V version	$V_{EN}=V_{IN}=3.6V$		15	30	$\mu$ A
Shutdown Supply Current at IN	$V_{EN} = GND$		0.32		$\mu$ A
IN Startup Voltage	$I_{OUT}=1mA$ , Hysteresis=200mV		0.75		V
IN Operation Voltage	After Start-up	0.55		5	V
Output Voltage at 5V		4.85	5	5.15	V
Output Voltage at 3.3V		3.2	3.3	3.4	V
Feedback Voltage		1.076	1.11	1.144	V
Switching Frequency			1.4		MHz
NMOS Switch On Resistance	$I_{SW}=100mA$		250		m $\Omega$
PMOS Switch On Resistance	$I_{SW}=100mA$		160		m $\Omega$
SW Leakage Current	$V_{OUT}=5.2V$ , $V_{EN}=GND$ , $V_{SW}=5.2V$ or $V_{SW}= 0V$			10	$\mu$ A
NMOS Switch Current Limit			1		A
Start-up Current Limit			1		A
Short Circuit Hiccup time	ON		1.3		ms
	OFF		33		ms
EN Input Current	$V_{EN}=5V$ or $0V$	-1	0	1	$\mu$ A
EN High Voltage	$V_{OUT}=5V$		0.75		V
EN low Voltage	$V_{OUT}=5V$		0.25		V
Thermal Shutdown	Rising, Hysteresis=25°C		155		°C

1.4MHz SOT23-6 1uA Ultra low IQ,Synchronous Boost

PIN DESCRIPTION

SOT23-6 PIN #	NAME	DESCRIPTION
1	OUT	Output pin. Bypass with a 4.7μF or larger ceramic capacitor closely between this pin and GND
2	GND	Ground Pin
3	EN	Enable pin for the IC. Drive this pin high to enable the part, low to disable.
4	IN	Input Supply Voltage. Bypass with a 4.7μF ceramic capacitor to GND
5	FB	Feedback Input. Add an external resistor divider from the OUT to FB and GND to set VOUT for adjustable output voltage. There is no FB pin for fixed voltage version. The pin is "Not Connected".
6	SW	Inductor Connection. Connect an inductor Between SW and the regulator output.

TYPICAL CHARACTERISTICS

(Typical values are at T<sub>A</sub> = 25°C unless otherwise specified.)

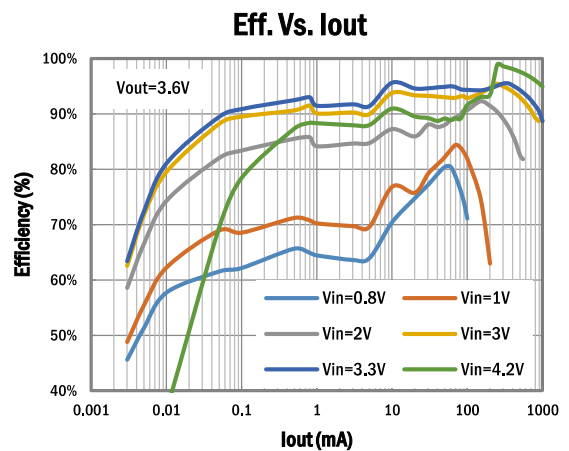
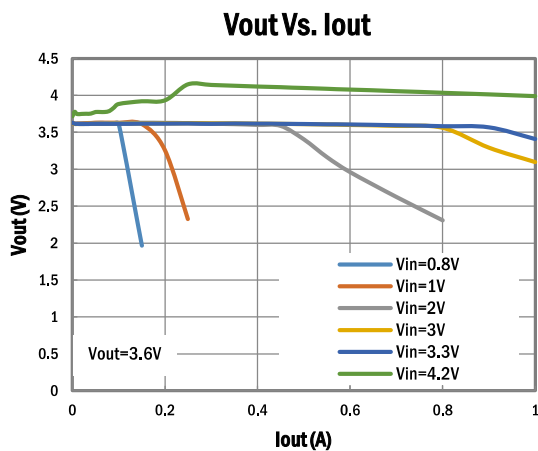
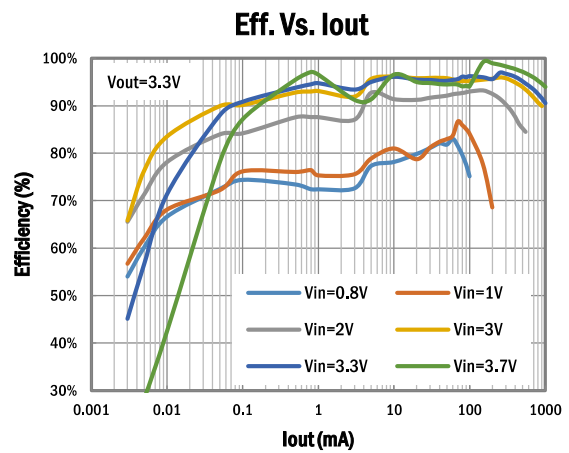
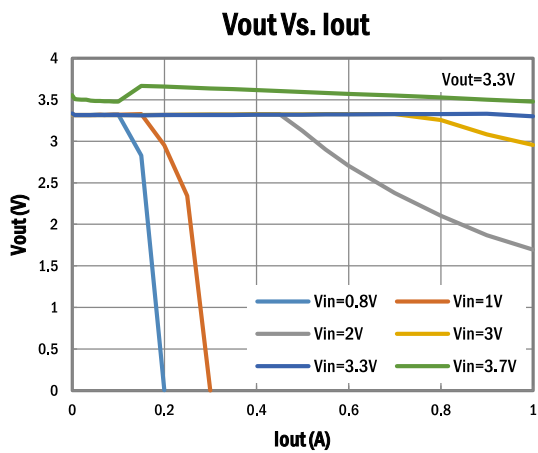

**1.4MHz SOT23-6 1uA Ultra low IQ,Synchronous Boost**

**TYPICAL CHARACTERISTICS cont'd**

(Typical values are at  $T_A = 25^\circ\text{C}$  unless otherwise specified.)

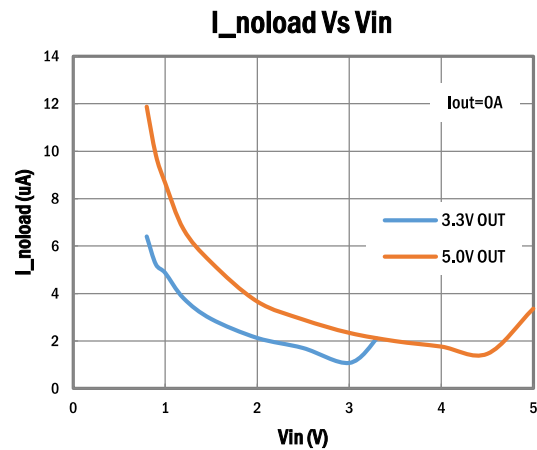
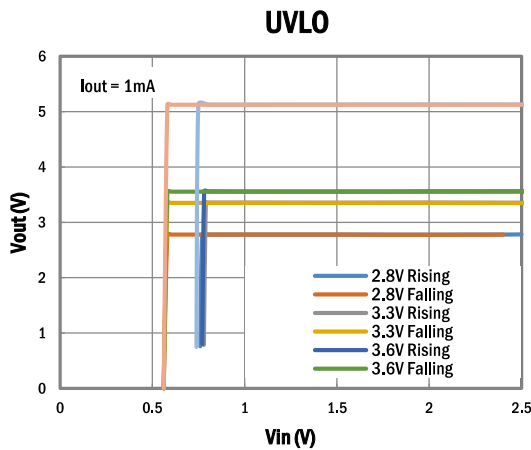
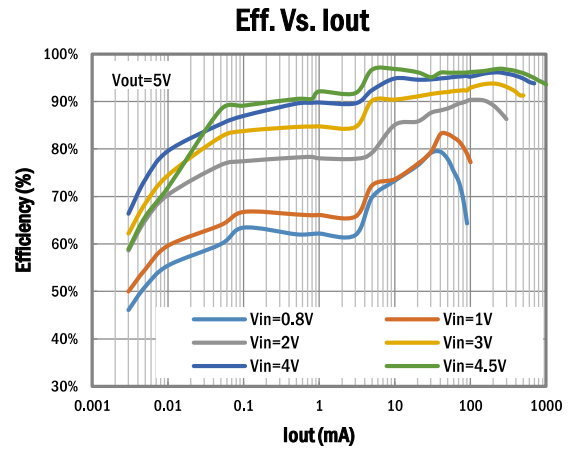
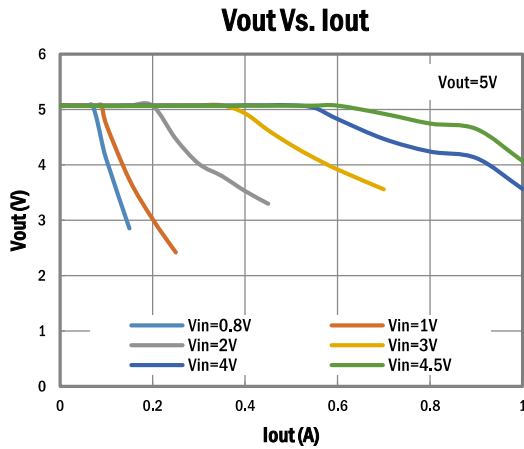

**APPLICATION INFORMATION**

**Loop Operation**

YB1161s is a high efficiency synchronous step-up converter with ultra-low quiescent current down to 1 $\mu\text{A}$ . It integrates a 250m $\Omega$  Low Side Main MOSFET and 160m $\Omega$  synchronous MOSFET. It uses a PWM current-mode control scheme. An error amplifier integrates error between the FB signal and the internal reference voltage. The output of the integrator is then compared to the sum of a current-sense signal and the slope compensation ramp. This operation generates a PWM signal that modulates the duty cycle of the power MOSFETs to achieve regulation for output voltage.

The peak current of the NMOS switch is also sensed to limit the maximum current flowing through the switch and the inductor. The typical peak current limit is set to 1A. An internal temperature sensor prevents the device from getting overheated in case of excessive power dissipation.

**Ultra low current consumption at Light Load Operation**

Traditionally, a fixed constant frequency PWM DC/DC regulator always switches even when the output load is small.

1.4MHz SOT23-6 1uA Ultra low IQ,Synchronous Boost

When energy is shuffling back and forth through the power MOSFETs, power is lost due to the finite RDSONs of the MOSFETs and parasitic capacitances. At light load, this loss is prominent and efficiency is therefore very low. YB1161 employs a proprietary control scheme that improves efficiency in this situation by enabling the device into a power saving mode during light load and the no load quiescent current can be as low as 1µA.

Short-Circuit Protection

Unlike most step-up converters, the YB1161 allows for short circuits on the output. In the event of a short circuit, the device first turns off the NMOS when the sensed current reaches the current limit. When OUT drops below IN, the device then enters a linear charge period with the current limited same as with the start-up period. In addition, the thermal shutdown circuits disable switching if the die temperature rises above 155°C.

Adjustable Output Voltage Setting with FB pin

By adding a resistor divider at FB pin (R1 and R2 as shown in the circuit below), YB1161 can be set to any voltage level less than 5V at output node. The R2 is recommended to be 2Mohm or less, which will add about 0.5uA or more at output. The output voltage is set by following equation:

$$V_{out} = \frac{R1+R2}{R2} \times 1.11V$$

Application Circuit of Fixed Voltage Version

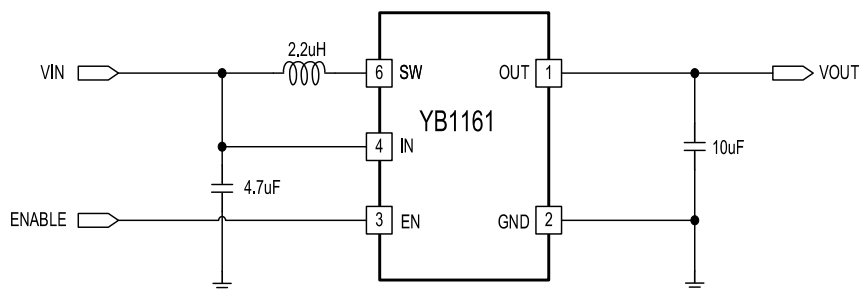

BLOCK DIAGRAM

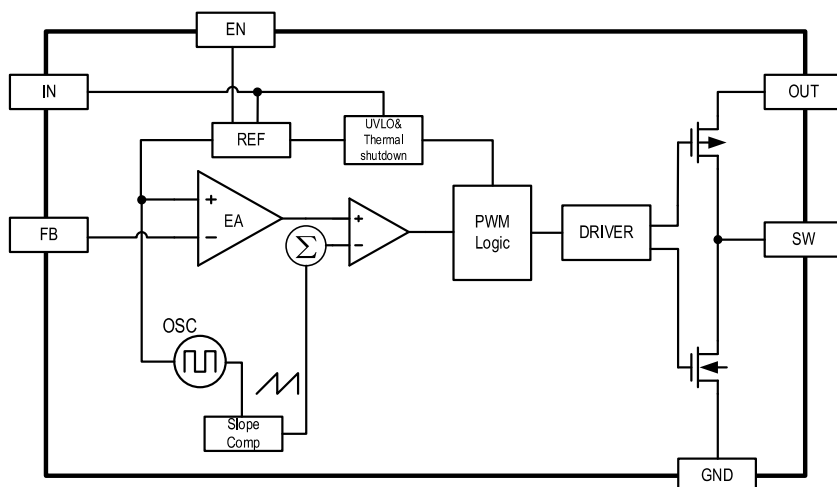

PCB GUIDELINES

PCB layout example for SOT23-6 package

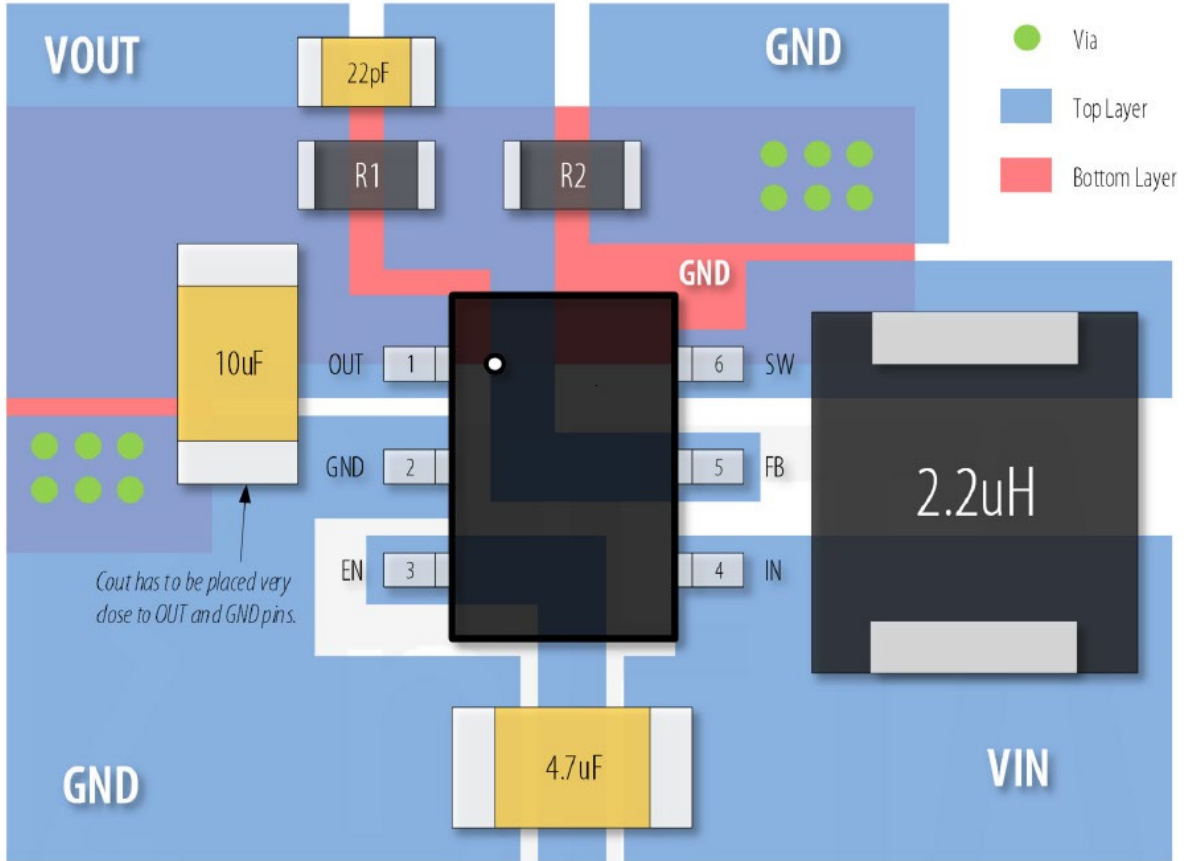

PCB layout example for DFN2x2-6 package

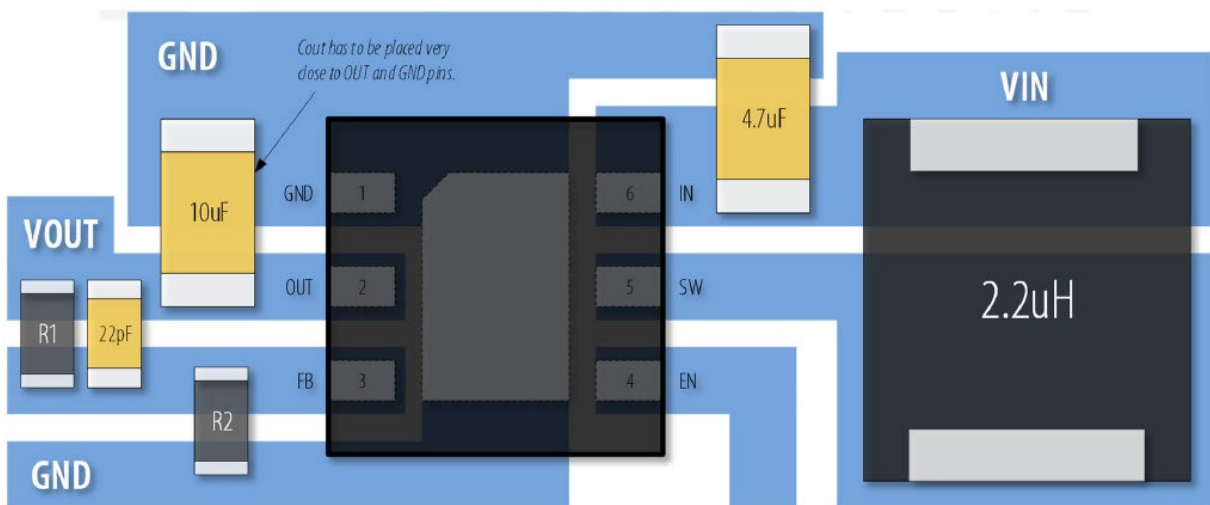

**1.4MHz SOT23-6 1uA Ultra low IQ,Synchronous Boost**

**PACKAGE OUTLINE**

Package: SOT23-6

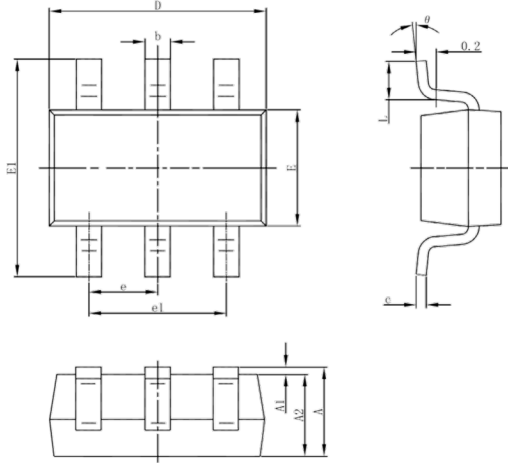

Symbol	Dimensions In Millimeters		Dimensions In Inches	
	Min	Max	Min	Max
A	1.050	1.250	0.041	0.049
A1	0.000	0.100	0.000	0.004
A2	1.050	1.150	0.041	0.045
b	0.300	0.500	0.012	0.020
c	0.100	0.200	0.004	0.008
D	2.820	3.020	0.111	0.119
E	1.500	1.700	0.059	0.067
E1	2.650	2.950	0.104	0.116
e	0.950(BSC)		0.037(BSC)	
e1	1.800	2.000	0.071	0.079
L	0.300	0.600	0.012	0.024
θ	0°	8°	0°	8°

Package: DFN2x2-6

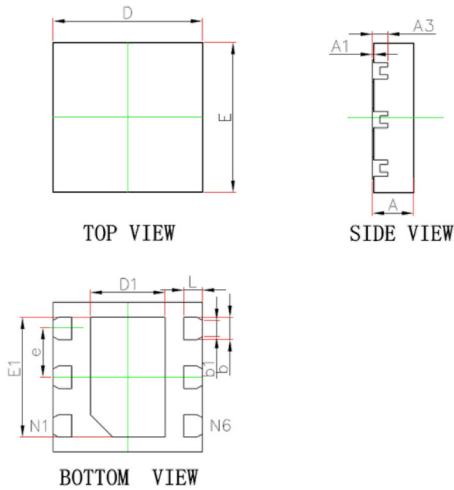

Symbol	Dimensions In Millimeters		Dimensions In Inches	
	Min	Max	Min	Max
A	0.700	0.800	0.028	0.031
A1	0.000	0.050	0.000	0.002
A3	0.203 REF.		0.008 REF.	
D	1.900	2.100	0.075	0.083
E	1.900	2.100	0.075	0.083
D1	0.900	1.100	0.035	0.043
E1	1.500	1.700	0.059	0.067
b	0.250	0.350	0.010	0.014
b1	0.220 REF.		0.009 REF.	
e	0.650 BSC.		0.026 BSC.	
L	0.174	0.326	0.007	0.013